

SLM80N03T

30V N -Channel MOSFET

General Description

This Power MOSFET is produced using Maple semi's advanced planar stripeTRENCH technology. This advanced technology has been especially tailored to minimize conduction loss, provide superior switching performance, and withstand high energy pulse in the avalanche and commutation mode.

Application

- PWM Application
- Load Switch
- Power Management

Features

- N-Channel:30V 80A
- $R_{DS(on)Typ} = 4.5m\Omega @ V_{GS} = 10V$
- $R_{DS(on)Typ} = 6.5m\Omega @ V_{GS} = 4.5V$
- Very Low On-resistance RDS(ON)
- LowCrss
- Fast switching
- 100% avalanche tested
- Improved dv/dt capability



DFN5*6

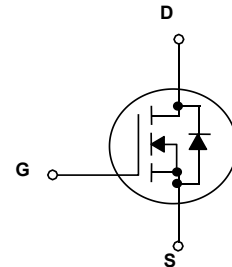
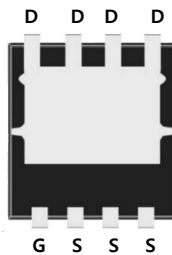

Absolute Maximum Ratings

$T_C = 25^\circ\text{C}$ unless otherwise noted

| Symbol | Parameter | SLM80N03T | Units |
|-----------------|---|-------------|---------------------|
| V_{DSS} | Drain-Source Voltage | 30 | V |
| I_D | Drain Current - Continuous ($T_C = 25^\circ\text{C}$) - Continuous ($T_C = 100^\circ\text{C}$) | 80 | A |
| | | 48 | A |
| I_{DM} | Drain Current - Pulsed (Note 1) | 320 | A |
| V_{GSS} | Gate-Source Voltage | ± 20 | V |
| E_{AS} | Single Pulsed Avalanche Energy | 56 | mJ |
| P_D | Power Dissipation ($T_C = 25^\circ\text{C}$) | 46 | W |
| $R_{\theta JC}$ | Thermal Resistance, Junction to Case | 2.72 | W/ $^\circ\text{C}$ |
| T_J, T_{STG} | Operating and Storage Temperature Range | -55 to +150 | $^\circ\text{C}$ |
| T_L | Maximum lead temperature for soldering purposes, 1/8" from case for 5 seconds | 300 | $^\circ\text{C}$ |

* Drain current limited by maximum junction temperature.

Electrical Characteristics $T_C = 25^\circ\text{C}$ unless otherwise noted

| Symbol | Parameter | Test Conditions | Min | Typ | Max | Units |
|--------|-----------|-----------------|-----|-----|-----|-------|
|--------|-----------|-----------------|-----|-----|-----|-------|

Off Characteristics

| | | | | | | |
|------------|------------------------------------|---|----|----|------|---------------|
| BV_{DSS} | Drain-Source Breakdown Voltage | $V_{GS} = 0\text{ V}, I_D = 250\text{ }\mu\text{A}$ | 30 | -- | -- | V |
| I_{DSS} | Zero Gate Voltage Drain Current | $V_{DS} = 30\text{ V}, V_{GS} = 0\text{ V}$ | -- | -- | 1 | μA |
| | | $V_{DS} = 24\text{ V}, T_C = 125^\circ\text{C}$ | -- | -- | 10 | μA |
| I_{GSSF} | Gate-Body Leakage Current, Forward | $V_{GS} = 20\text{ V}, V_{DS} = 0\text{ V}$ | -- | -- | 100 | nA |
| I_{GSSR} | Gate-Body Leakage Current, Reverse | $V_{GS} = -20\text{ V}, V_{DS} = 0\text{ V}$ | -- | -- | -100 | nA |

On Characteristics

| | | | | | | |
|--------------|-----------------------------------|---|-----|-----|-----|------------------|
| $V_{GS(th)}$ | Gate Threshold Voltage | $V_{DS} = V_{GS}, I_D = 250\text{ }\mu\text{A}$ | 1.0 | 1.5 | 2.5 | V |
| $R_{DS(on)}$ | Static Drain-Source On-Resistance | $V_{GS} = 10\text{ V}, I_D = 30\text{ A}$ | -- | 4.5 | 5.0 | $\text{m}\Omega$ |
| | | $V_{GS} = 4.5\text{ V}, I_D = 20\text{ A}$ | - | 6.5 | 10 | |

Dynamic Characteristics

| | | | | | | |
|------------|------------------------------|--|----|------|---|-------------|
| C_{iss} | Input Capacitance | $V_{DS} = 15\text{ V}, V_{GS} = 0\text{ V},$ $f = 1.0\text{ MHz}$ | -- | 1600 | - | pF |
| C_{oss} | Output Capacitance | | -- | 250 | - | pF |
| C_{riss} | Reverse Transfer Capacitance | | -- | 210 | - | pF |

Switching Characteristics

| | | | | | | |
|--------------|---------------------|---|--|------|------|----|
| $t_{d(on)}$ | Turn-On Delay Time | $V_{GS} = 10\text{ V}, V_{DS} = 15\text{ V},$ $R_G = 3\text{ }\Omega, I_D = 30\text{ A}$ | -- | 7.2 | -- | ns |
| t_r | Turn-On Rise Time | | -- | 14.0 | -- | ns |
| $t_{d(off)}$ | Turn-Off Delay Time | | -- | 35.5 | -- | ns |
| t_f | Turn-Off Fall Time | | -- | 10 | -- | ns |
| Q_g | Total Gate Charge | | $V_{DS} = 15\text{ V}, I_D = 30\text{ A},$ $V_{GS} = 10\text{ V}$ | -- | 34.0 | -- |
| Q_{gs} | Gate-Source Charge | -- | | 8.45 | -- | nC |
| Q_{gd} | Gate-Drain Charge | -- | | 7.2 | -- | nC |

Drain-Source Diode Characteristics and Maximum Ratings

| | | | | | |
|----------|--|----|----|-----|---|
| I_S | Maximum Continuous Drain-Source Diode Forward Current | -- | -- | 80 | A |
| I_{SM} | Maximum Pulsed Drain-Source Diode Forward Current | -- | -- | 320 | A |
| V_{SD} | Drain to Source Diode Forward Voltage, $V_{GS} = 0\text{ V}, I_{SD} = 30\text{ A}, T_J = 25^\circ\text{C}$ | -- | -- | 1.2 | V |

Notes:

1. Repetitive Rating: Pulse Width Limited by Maximum Junction Temperature
2. EAS condition: $T_J = 25^\circ\text{C}, V_{DD} = 15\text{ V}, V_G = 10\text{ V}, R_G = 25\Omega, L = 0.5\text{ mH}, I_{AS} = 15\text{ A}$
3. Pulse Test: Pulse Width $\leq 300\mu\text{s}$, Duty Cycle $\leq 0.5\%$

N- Channel Typical Characteristics

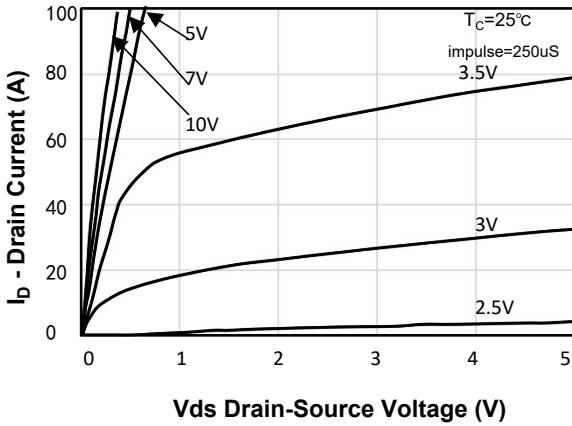

Figure 1. On-Region Characteristics

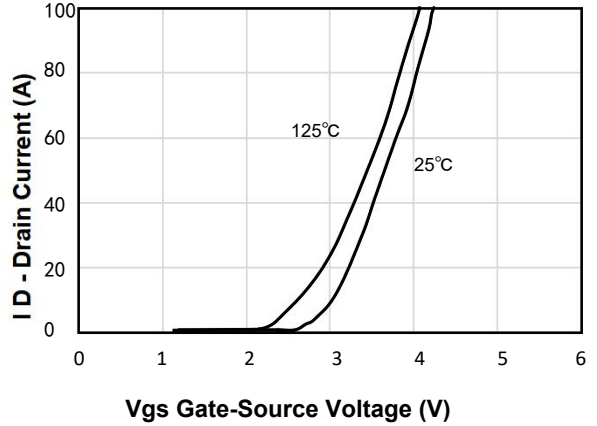

Figure 2. Transfer Characteristics

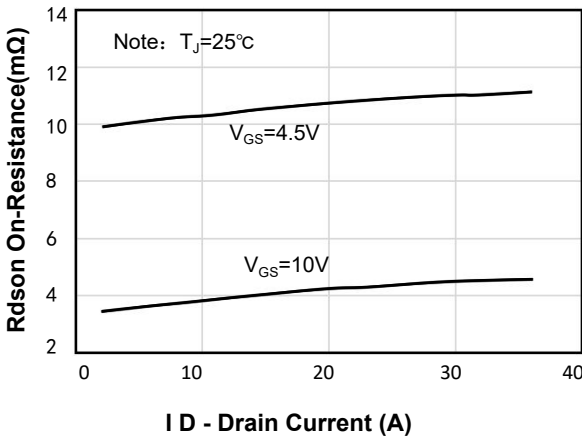

Figure 3. On-Resistance Variation vs Drain Current and Gate Voltage

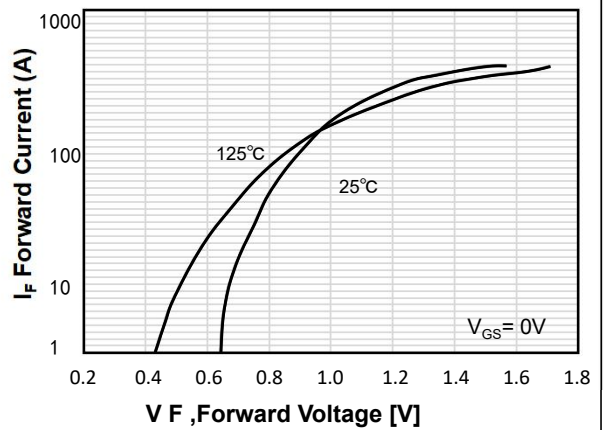

Figure 4. Body Diode Forward Voltage Variation with Source Current and Temperature

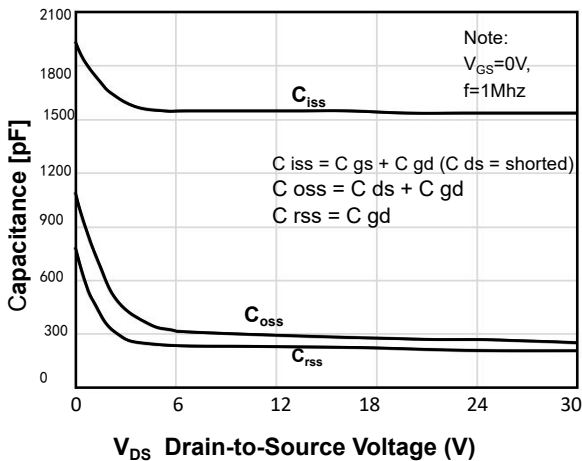

Figure 5. Capacitance Characteristics

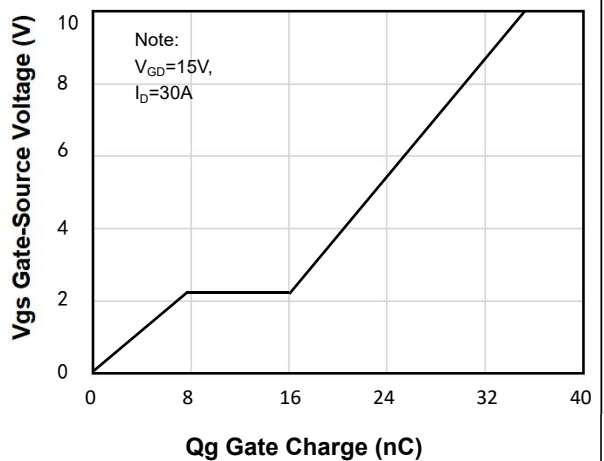

Figure 6. Gate Charge Characteristics

N- Channel Typical Characteristics (Continued)

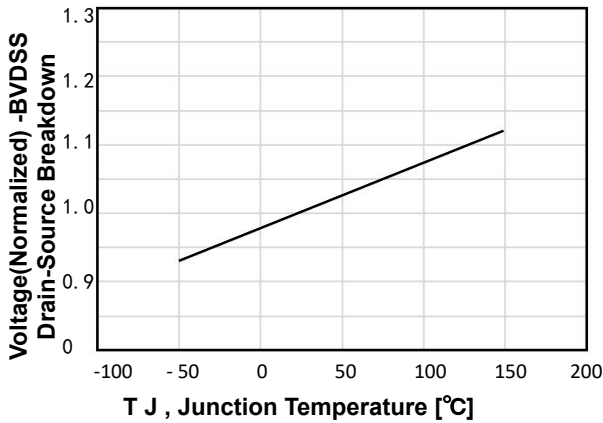

Figure 7. Breakdown Voltage Variation vs Temperature

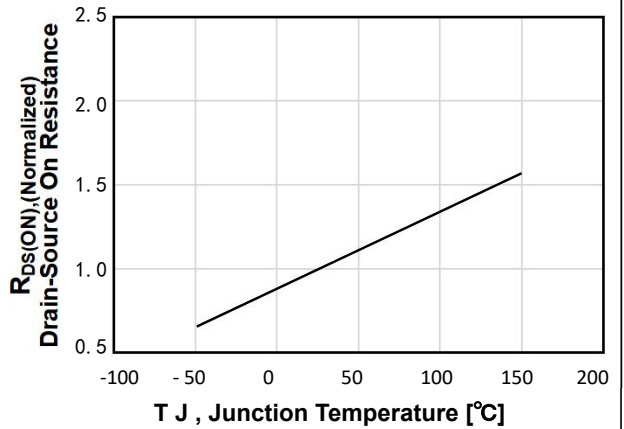

Figure 8. On-Resistance Variation vs Temperature

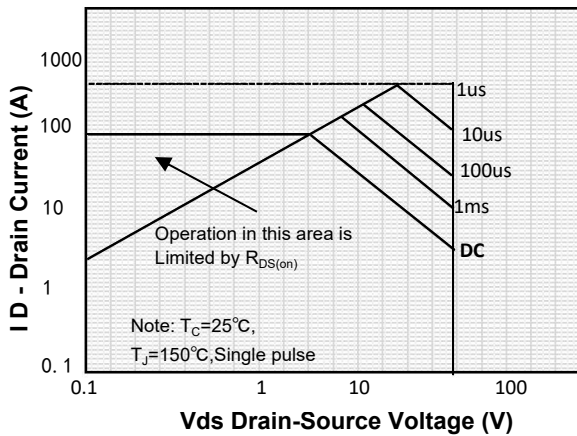

Figure 9. Maximum Safe Operating Area

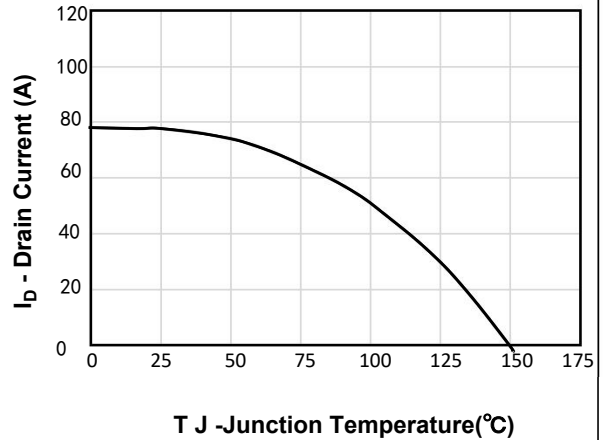

Figure 10. Maximum PContinuous Drain Current vs Case Temperature

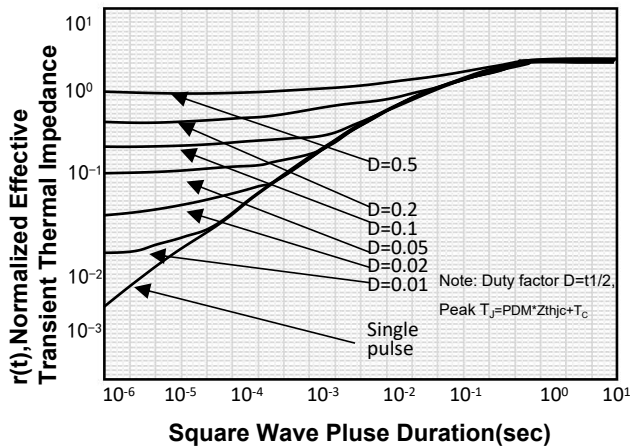
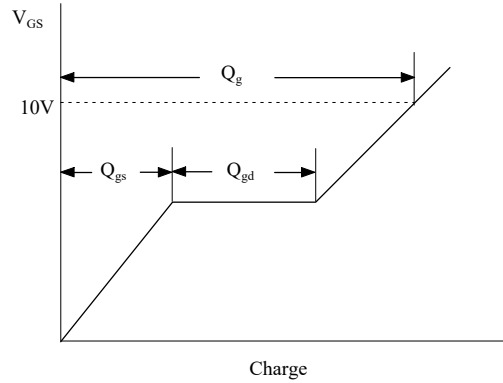
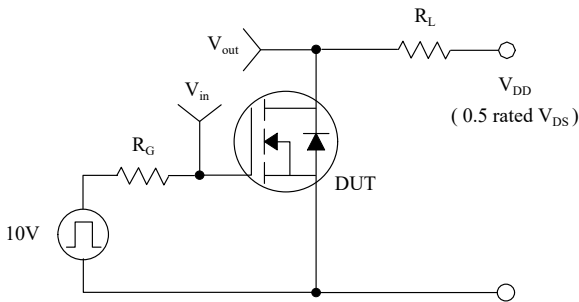

Figure 11. Transient Thermal Response Curve

Gate Charge Test Circuit & Waveform



Resistive Switching Test Circuit & Waveforms



Unclamped Inductive Switching Test Circuit & Waveforms

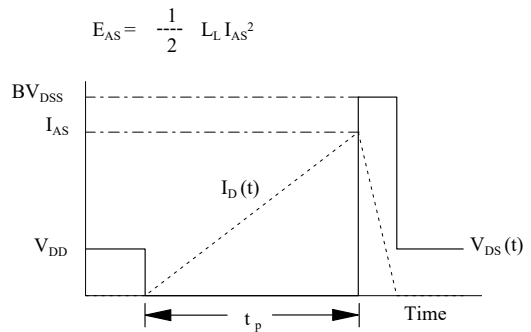
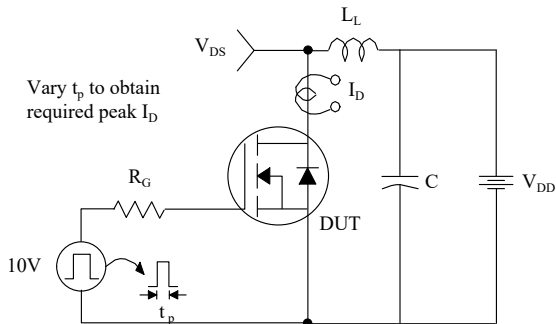

Peak Diode Recovery dv/dt Test Circuit & Waveforms

